

***New Directions of US–Japan
Higher Education Cooperation
in the Globalizing World:
In the aftermath of
the Great East Japan Earthquake***

September 8, 2011

Ambassador Room, The Embassy Row Hotel

Saya SHIRAIISHI
The University of Tokyo

We are grateful for all the assistance and support given to us by so many people in the world.

It is undeniable that we have lost some confidence in ourselves.

Previously, we might have placed ourselves as the good student of Western Modernity, and the good teacher for the people in Asia for that matter.

Now, I remember the following epic poem from the 19th century Java.

Turing away from vain desire
For the delight of teaching the young
Rendered in song beautiful
Embellished wrought elegantly
That perfectly practice be the knowledge sublime

.....

Imagine how great a guru to be

.....

All satisfied my students would be
Thinking it knowledge brilliantly new

.....

So one thing kind of worries me
Should ever I get a student who's smart
Then I'd be in fearful dread

.....

(by the court-poet of Java, Ronggawarsita, 1802-1873)

Imagined Learning hierarchy

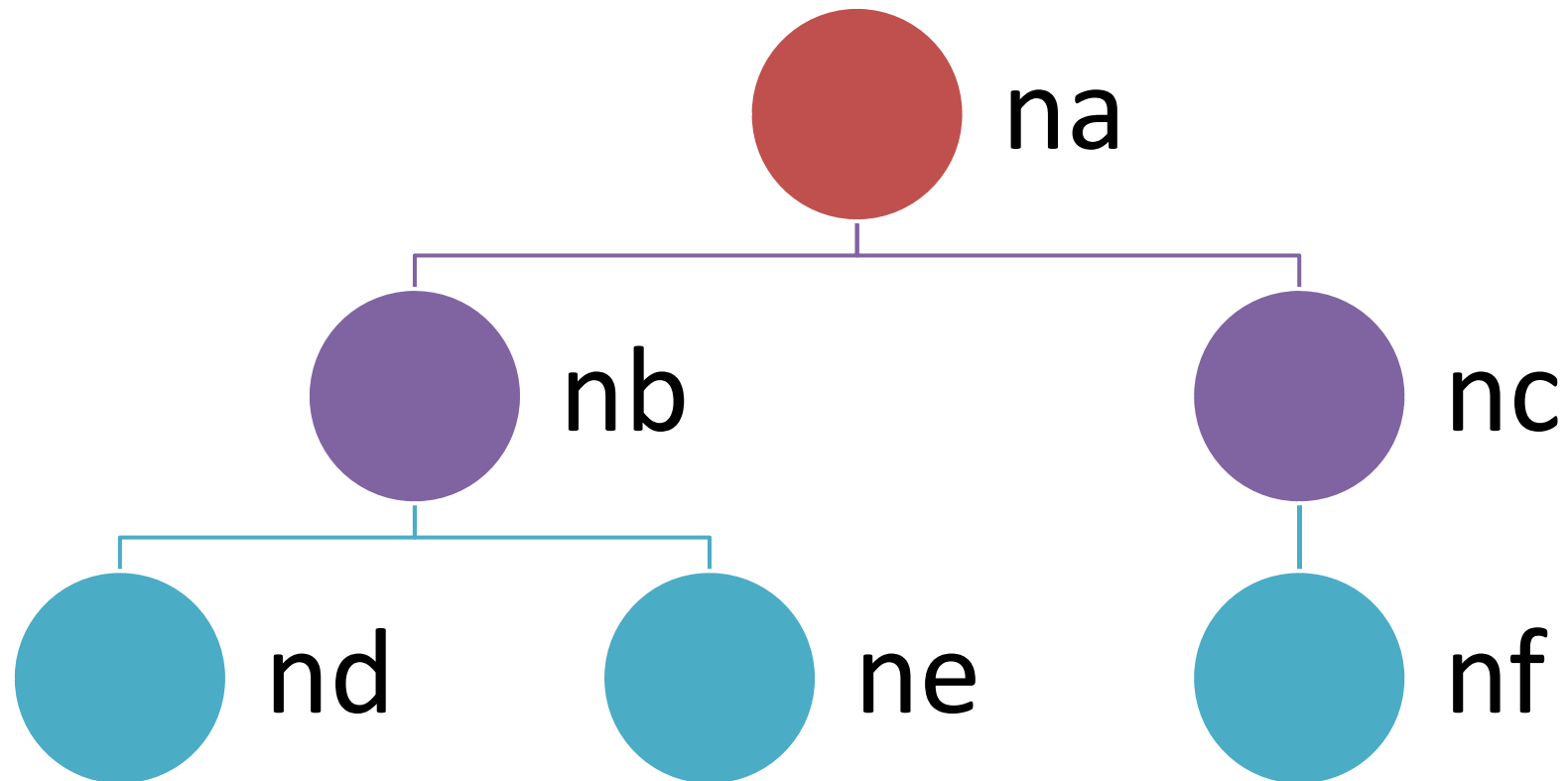

It is high time for us to change that kind of old hierarchical perspective of the world of learning.

In the aftermath of the Great East Japan Earthquake, I would like to propose to ourselves "Let us get relaxed."

Prof. *Kuroda has said:*

“The increase in Asian student mobility and Asian inter-university partnerships underscores the need to establish policy for a regional framework for international cooperation.

Student mobility is also on the rise between North America and Asia.”

→ The institutionalization of university exchange network which includes both North America and Asia is needed.

MECCA Pilgrimage Model

of University Student Exchange:
the journey to the Holy Land

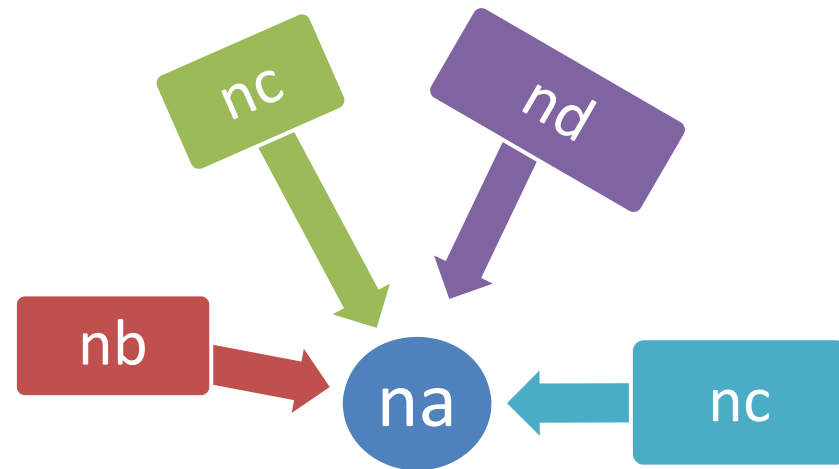
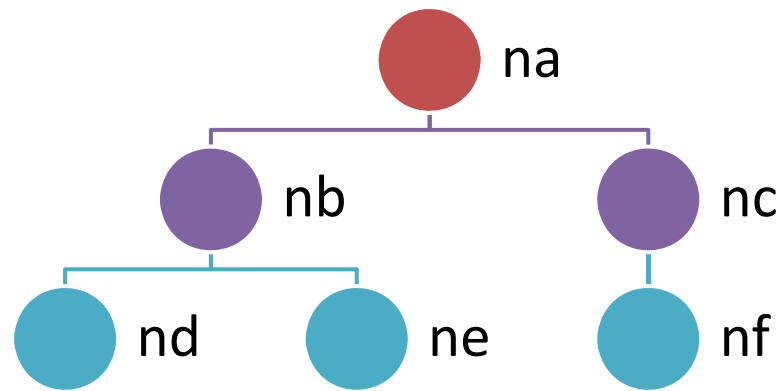

OHENRO Pilgrimage Model

of University Student Exchange:
the circulatory journeys to the holy lands
<<http://www.maenaem.com/henro/bas.htm>>

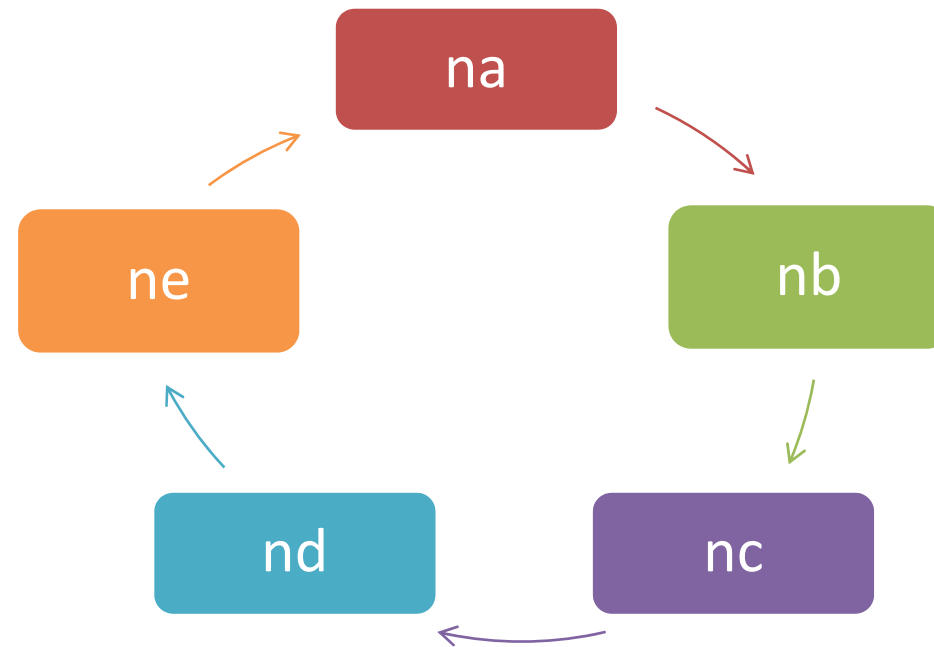

OHENRO Pilgrimage Model of student exchange:

1. The students get started wherever they like.
2. The diversity among the universities is the motivation and the engine of the students' mobility.
3. They may stop wherever they like, and they may re-start moving whenever they like.
4. They might get married, find jobs, have children on the way.
5. The local language training centers offer the summer school where the students from different universities (and nations) live together and get to know each other.

Campus PACIFIC

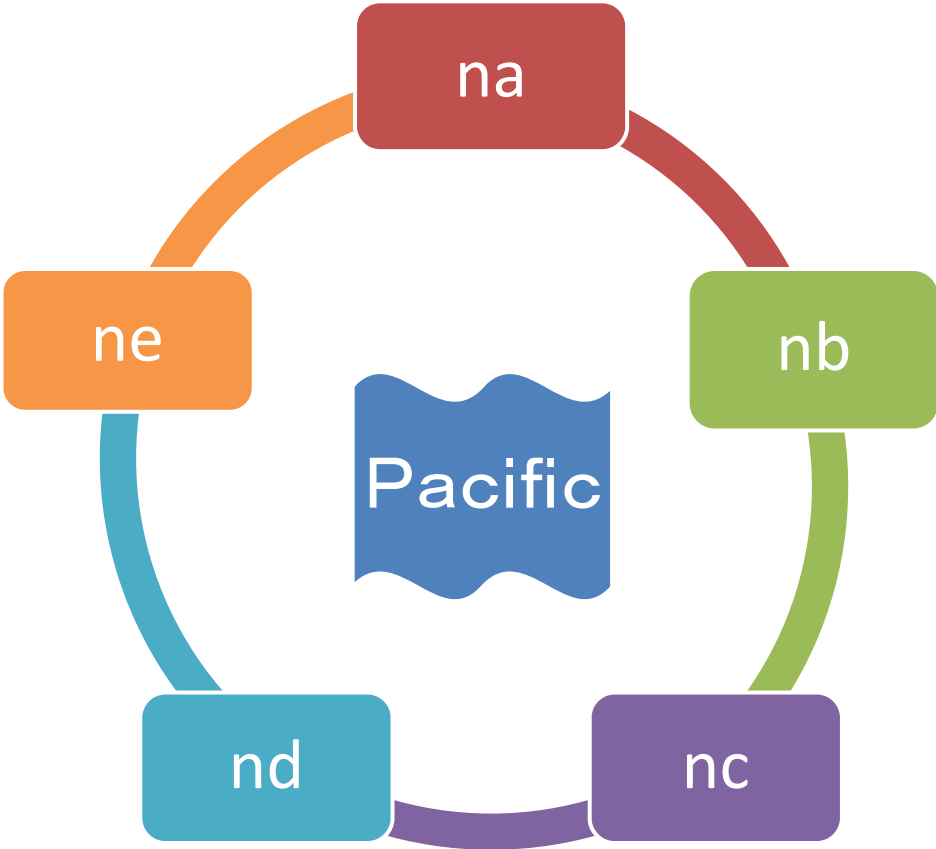

KOMIKE (Manga Fair) at Tokyo Big Sight

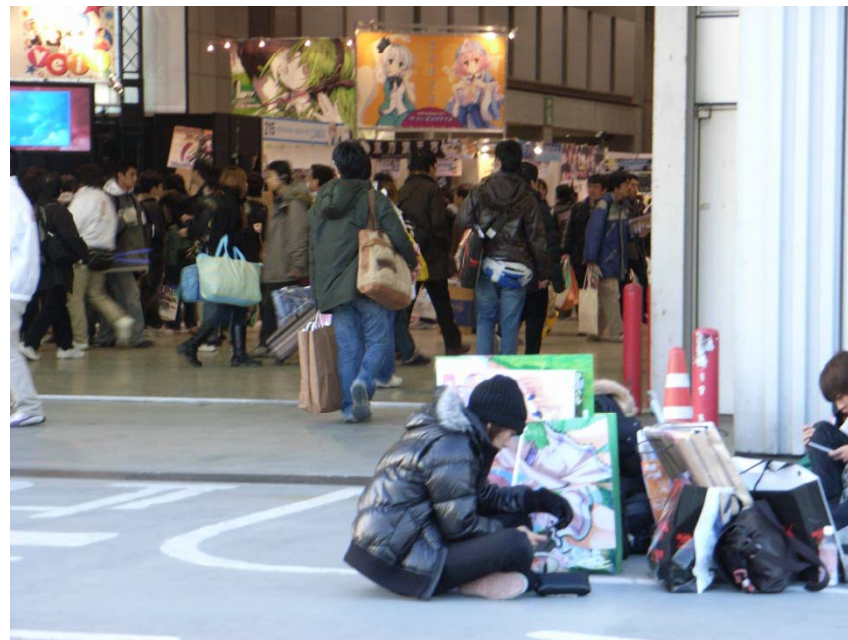

University of Taiwan Manga Fair





Manga Shops at Manga Street in Bangkok in 2002



Jakarta in 2008

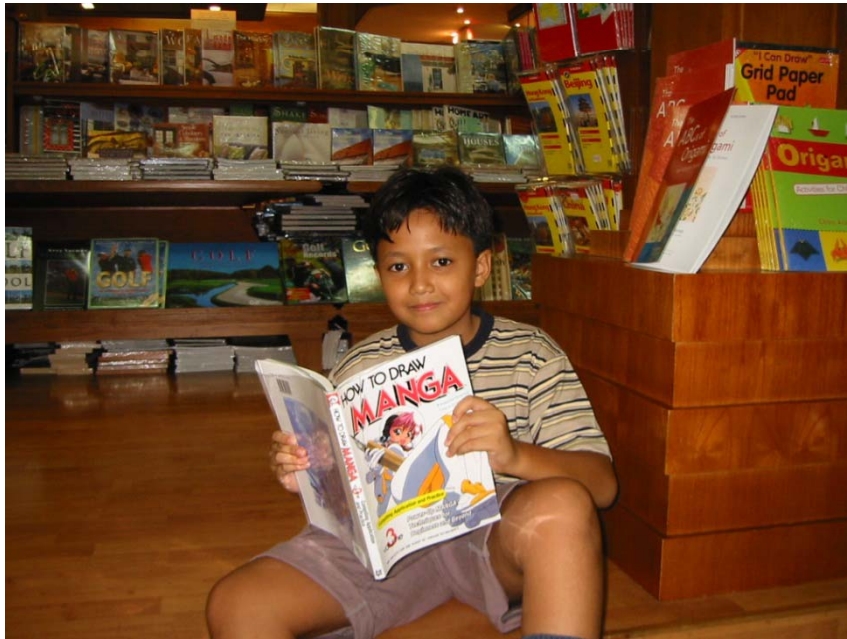

Manga Seminar at FPT University in Ha Noi



After the Manga Seminar



Manga Café in Paris



Manga & Anime Fans in Warsaw



Thank you